

# CCA-02E/SLD

- Lower maintenance costs
- Lower power consumption
- LED technology
- Zones 1, 2, 21, 22

*Tempered glass with polycarbonate lenses*

*Brackets in galvanised steel*

*Sun shades*

*Connections*



# CCA-02E/S...LD LED traffic lights





CCA-02E/S...LD series traffic light system is the result of research and development activities into the new LED lighting technology that can achieve optimum light efficiency, immediate power response times and very low power consumption. These Ex d IIC traffic lights are suitable for regulating traffic in chemically aggressive industrial environments or potentially explosive areas classified as Zone 1 - 2 - 21 or 22.

It is made of low copper content aluminium and features tempered glass, coloured polycarbonate lenses and painted steel sun shades. The benefits offered by the new CCA- 02E/S...LD system are as follows: lower maintenance costs, better visibility in critical conditions thanks to the LED lamps, better reliability thanks to the guaranteed continuous light even if one LED fails and, lastly, the lack of any "phantom" effect.

**Application sectors:**

							
Oil refineries	Chemical and petrochemical plants	Fuel tanker loading/unloading areas	Offshore plants	Emergency exits	Combustible liquid depots	Oil loading/unloading jetties	100% Cortem product

## CERTIFICATION DATA

<b>Classification:</b>	Group II	Category 2GD		
<b>Installation:</b> EN 60079.14	zone 1 - zone 2 (Gas)	zone 21 - zone22 (Dust)		
<b>Marking:</b>	CE 0722 Ex II 2GD Ex d IIC T6 Gb - Ex tb IIIC T85°C Db IP66			
<b>Certification:</b>	ATEX	CESI 01 ATEX 036X		
<b>Standards:</b>	CENELEC EN 60079-0: 2006, EN 60079-1: 2007, EN 61241-0: 2006, EN 61241-1: 2004 and EUROPEAN DIRECTIVE 2014/34/UE European Directive 2004/108 Electromagnetic compatibility European Directive 2012/19/UE, 2002/96/CE, 2003/108/CE WEEE European Directive 2011/65/UE RoHS			
<b>Class temperature:</b>	 85°C (T6)			
<b>Ambient temperature:</b>	 Standard -20°C +55°C 	 Special -40°C +55°C 		
<b>Degree of protection:</b>	IP66			

## CCA-02E/S...LD LED traffic lights

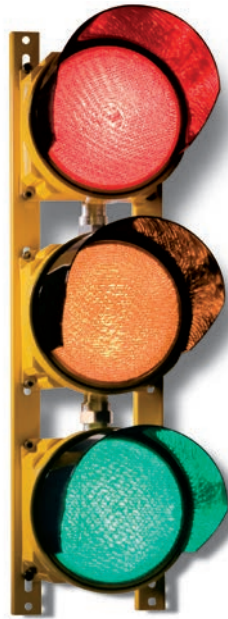

ORIGINAL PRODUCT

### MECHANICAL FEATURES

<b>Body and internal ring:</b>	Low copper content aluminium alloy
<b>Internal frame and bracket:</b>	Aluminium
<b>Sun shades:</b>	Galvanised steel
<b>Gasket:</b>	Acid, hydrocarbon and high temperature resistant silicone
<b>Glass face:</b>	Shock and high temperature resistant tempered glass
<b>Fresnel lens:</b>	Polycarbonate
<b>Coloured lens:</b>	Red, yellow and green in polycarbonate
<b>Bolts and screws:</b>	Stainless steel
<b>Mounting:</b>	See "CCA-02E/S...LD series dimensional drawings"
<b>Entries:</b>	1 x 3/4" NPT
<b>Coating:</b>	Epoxy coating Ral 1003 (Signal yellow). Fixing brackets in painted galvanised steel upon request
<b>Corrosion Resistance:</b>	The STANDARD of the aluminium alloy used by Cortem has passed the tests required by standards EN60068-2-30 (hot/humid cycles) and EN60068-2-11 (salt mist tests)

### ELECTRICAL FEATURES

#### LED:



- 4 LEDs installed on plate  
if one or more of the LEDs fails, the lamp keeps on working)
- High resistance to vibration (longer lifespan if installed in severe operating conditions)
- Estimated lifespan 50,000 hours
- Maintenance costs estimated to be about one tenth compared with systems currently in use

<b>Power supply:</b>	High efficiency electronic system. Protection against short circuit, overloading and restore system
<b>Rated voltage:</b>	230Vac $\pm$ 10%
<b>Rated frequency:</b>	50/60 Hz
<b>Connection:</b>	Direct entries for cables to terminal board L, N, Pe. Max section 4mm <sup>2</sup>
<b>Power factor:</b>	0.96
<b>Wiring:</b>	Silicone rubber cables with glass braid protection against high temperatures

### ACCESSORIES AVAILABLE / SPECIAL REQUESTS

Cable gland: NEVB2NB for armoured cable or NAVB2NB for non-armoured cable  
Rated voltage 24 Vac/dc (code CCA-02E/S2LD**24**)  
Rated voltage 110-240 Vac (code CCA-02E/S2LD**5**)  
LED traffic light units with Wi-Fi system

# CCA-02E/S...LD series selection chart

Code	LED colour	Number of signalers	Watt	Weight kg	 mm
CCA-02E/S1-1LD	GREEN	1	6W	8	90x190x320
CCA-02E/S1-2LD	YELLOW	1	6W	8	90x190x320
CCA-02E/S1-3LD	RED	1	6W	8	90x190x320
CCA-02E/S2-4LD	GREEN + RED	2	6W	16	230x580x320
CCA-02E/S2-5LD	GREEN + YELLOW	2	6W	16	230x580x320
CCA-02E/S2-6LD	RED + YELLOW	2	6W	16	230x580x320
CCA-02E/S3-7LD	RED + GREEN + YELLOW	3	6W	24	230x870x320

## DIMENSIONAL DRAWING

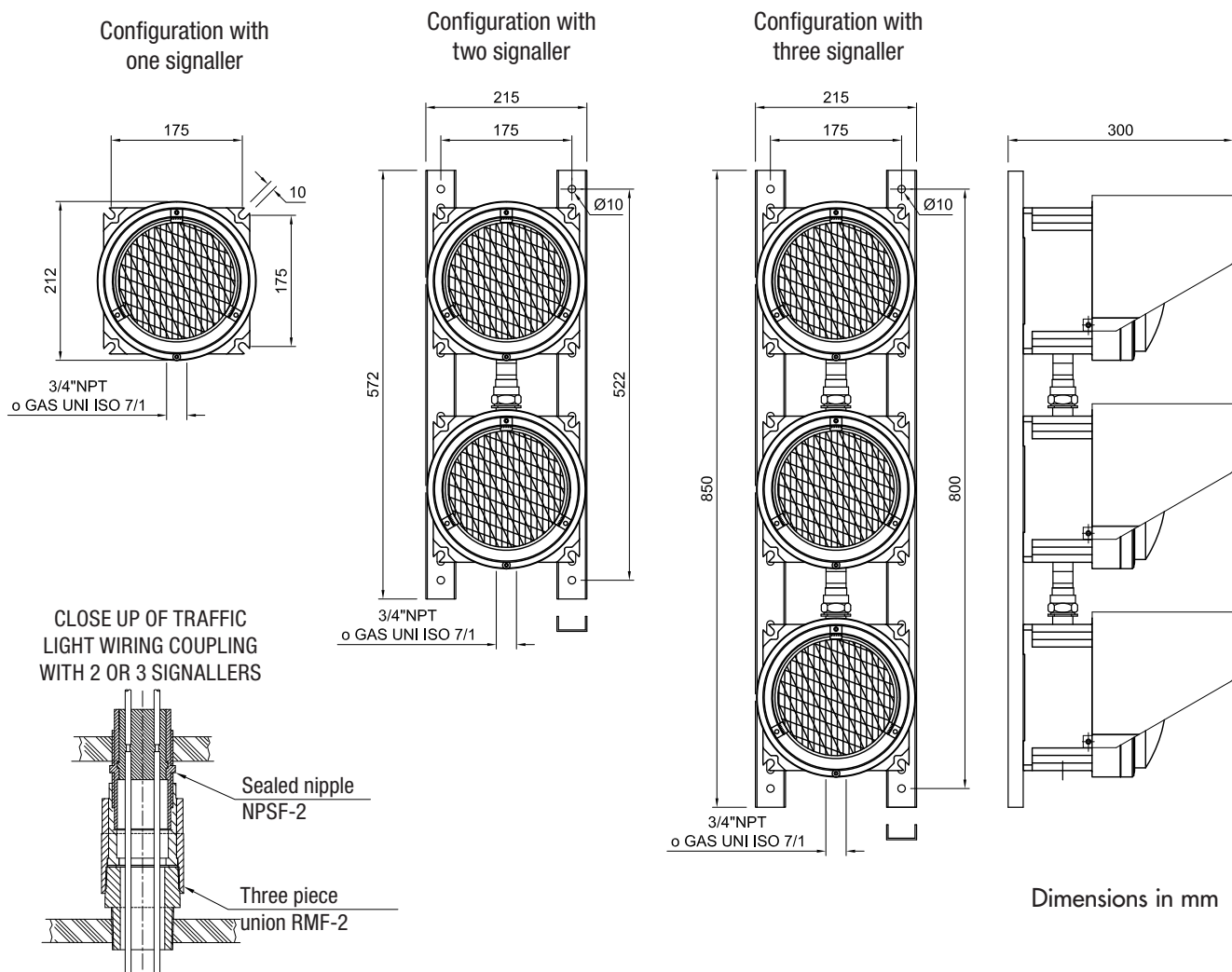



## Accessories and spare parts available on request for CCA-02E/S...LD

ILLUSTRATION	DESCRIPTION	FEATURES	CODE	KEY
	Coloured prismatic polycarbonate lens	Red lens	G-572R	
		Yellow lens	G-572G	
		Green lens	G-572V	
	Fresnel lens	Material: polycarbonate	G-573	
	Protective hood	Material: black painted steel	K-320	
	Electronic power supply	240V ±10%	RV-11LED	
	Gasket	Material: NBR	K20-131	
	LED plate	Red LED board	G-614R	
		Yellow LED board	G-614G	
		Green LED board	G-614V	
	Cable gland	For models and codes, visit <a href="http://www.cortemgroup.com">www.cortemgroup.com</a>	NAVB2NB NEVB2NB	 

# CCA-02E/S...LD traffic light features

## EXPLODED DIAGRAM OF CCA-02E/S1-3LD TRAFFIC LIGHT

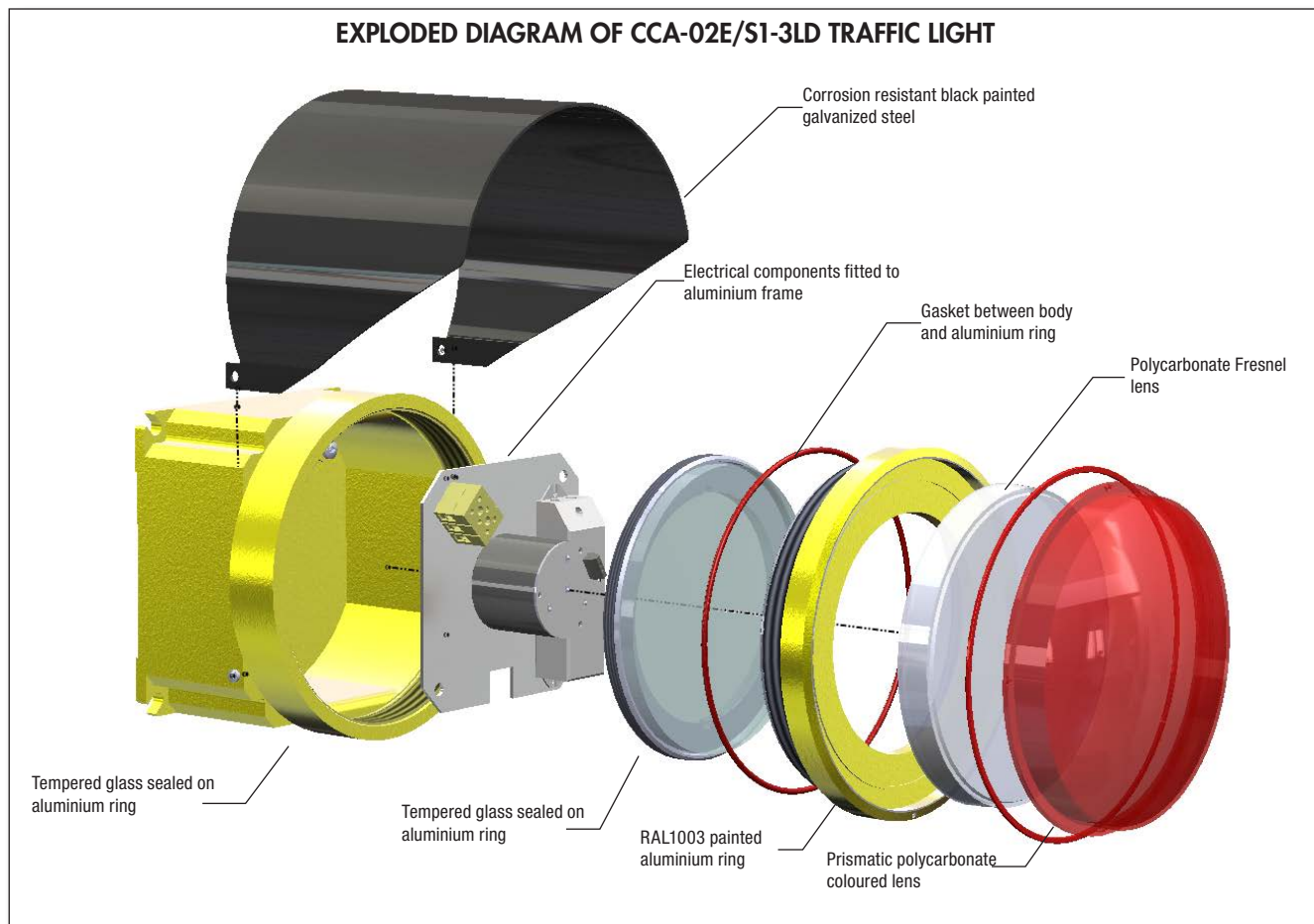

## WIRING DIAGRAM

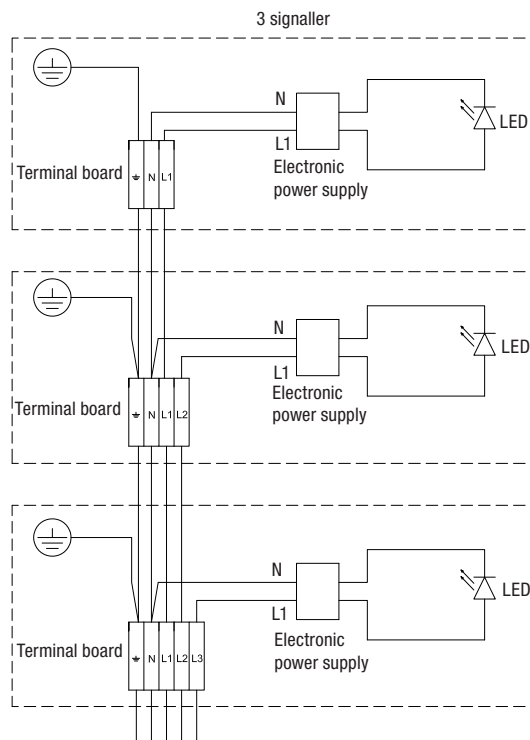
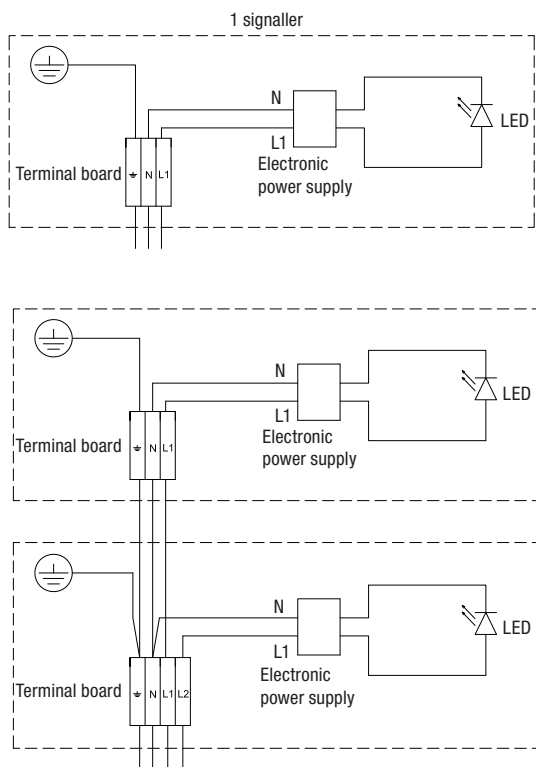

## LED traffic light units with Wi-Fi system

The Wi-Fi traffic light arose from the need to control dangerous roadway junctions, harnessing the technology of RF (radio frequency) communication.

It is common knowledge that individual units must communicate with one another for the purpose of coordinating the correct light colour to display to flowing traffic. The use of RF technology eliminates the need to dig up the road surface in order to “bury” the cables and / or sensors required in the systems used today.

In addition, Wi-Fi technology facilitates the use of a traffic light system in situations where a short-term solution, rather than a permanent installation, is required.



The units are available in two different combinations:

Model	Cortem custom products	Unit specifications
TL2LDWI	EJB-1A + CCA-02E/S2-4LD	Dual aspect R-G operation
TL3LDWI	EJB-1A + CCA-02E/S3-7LD	Three aspect R-Y-G operation

Both combinations are powered by mains electricity (100-240Vac, 50-60Hz). The covers of the EJB-1A housings act as the control panel.

These are characterised by the following elements:

- Two indicator lights (red and green)
- A potentiometer for adjustment over time
- A five-position selector to set the operating mode

The EJB-1A housing contains:

- The TLCU circuit board
- The transformer
- Galvanic isolator for the installation of the antenna in hazardous areas

External antenna:

- Frequency range: 2400-2500MHz
- RF connector: N female
- Omnidirectional

Communication between the traffic lights (with  $2 \leq n \leq 4$ ) which make up the “Traffic Light System” is performed by means of Master-Slave technology. For this reason, the traffic light system will always have a single Master device and at least one Slave device. To this end, the five position selector makes it possible for each traffic light to select from the following operating modes:

Selector position	Operating mode
OFF	System powered OFF
Master	Device on which it is possible to adjust and set the duration of time the aspects of the entire traffic light system are ON
Slave-1	Slave-1
Slave-2	Slave-2
Slave-3	Slave-3

Communication between Master and Slave-n is twoway. Therefore, the Slave-n transmits its status to the Master device and, at the same time, receives commands to switch the aspect ON. This information exchange occurs by means of RF serial communication via the UART peripheral of the TLCU microcontroller. This peripheral interfaces with an XBee module which provides a RF transmission equivalent to communication via serial cable. Lastly, communication complies with the IEEE 802.15.4 protocol.

# LED traffic light units with Wi-Fi system

## Principles of operation

### Sequence for powering ON the traffic light system

The sequence for power ON the traffic lights is defined, unambiguous and must be performed in the following order:

1. Slave-n devices are configured/powered ON
2. The Master device is configured/powered ON

This requirement derives from the fact that the Master, when powered ON, checks for the presence of other traffic light units. It then acquires the unique address (8+8 bit MAC address) of each unit which it will then use to control them. Therefore, if a Slave fails/powers OFF and has to be replaced, the Master must be restarted. In any event, in view of the internal reaction times, the correct activation Master and Slave-n is ensured, even if they are powered ON simultaneously.

### Sequence for powering ON the aspects, and timings management

For the Master device, the powering ON sequence of the aspects is the reverse of the sequence used for the Slave-n device (with n = 1, 3). Conversely, the Master device has the same powering ON sequence as that of the Slave-2 aspects. For this reason it is recommended to select:

- Master + Slave-1/3 for streets with alternating one-way traffic
- Master + Slave-2 + Slave-1/3 three-way junctions
- Master + Slave-1 + Slave-2 + Slave-3 for four-way junctions providing traffic lights on a case by case basis as shown in the figure below::

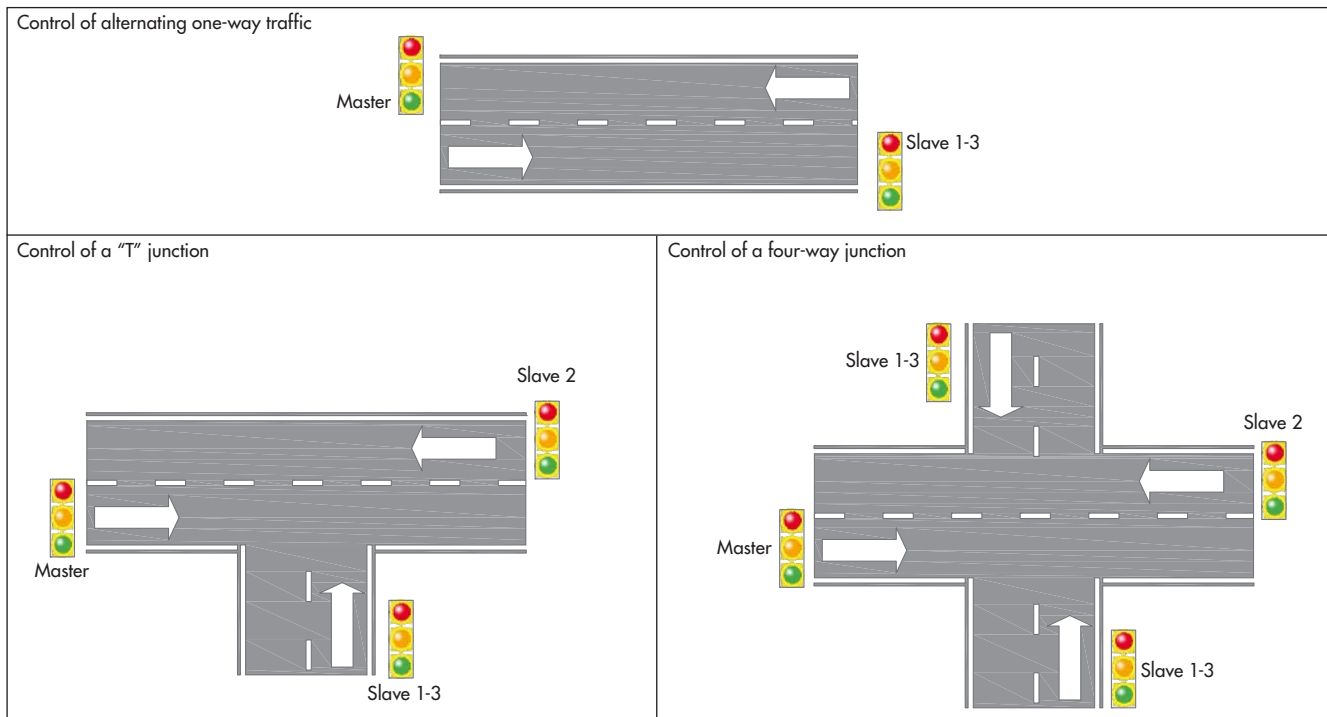

## Errors and fault signals

Each traffic light unit (two or three aspect units configured as Master or Slave-n) has specific operating statuses which, in the event of an error/fault, are reported by the two indicator lights located on the control panel.

Device status	Green indicator light	Red indicator light	Aspect status
Normal operation/Correct coordination	ON	OFF	According to sequence
Searching for Master/Slave	Flashing	OFF	Flashing yellow if 3 aspects Flashing red if 2 aspects

Specifically, each device recognises the following errors:

- General power supply fault or no power (error Pwr\_err)
- RF communication fault (module, antenna, interference...) (error RF\_err)
- Aspect transformer fault (error 18V\_err)